

ISSN 2217-5539



**Scientific Publications
of the State University
of Novi Pazar**

Series A

**Applied Mathematics,
Informatics and Mechanics**

No 2

Volume 4

2012

Area Editors

Teodor M. Atanacković

Solid state mechanics

e-mail: atanackovic@uns.ac.rs

Gradimir V. Milovanović

Approximation theory,
Numerical analysis

e-mail: gvm@megatrend.edu.rs

Emina I. Milovanović

Parallel computing,
Computer architecture

e-mail: ema@elfak.ni.ac.rs

Nikolić-Stanojević

Methods in mechanics

e-mail: stanojevic@np.ac.rs

M. Pilipović

Integral Analysis

e-mail: pilipovic@dimi.uns.ac.rs

Božidar V. Stanić

Plasma physics

e-mail: bozidar.stanic@etf.rs

Mile K. Stojčev

Computer engineering,
Digital signal processing

e-mail: mile.stojcev@elfak.ni.ac.rs

Technical Editors: E. I. Milovanović, Faculty of Electronic Engineering,

e-mail: ema@elfak.ni.ac.rs

V. B. Nikolić-Stanojević, State University of Novi Pazar,

e-mail: vstanojevic@np.ac.rs

D. Č. Dolčanin, State University of Novi Pazar,

e-mail: dolcanin_d@yahoo.com

S. Eminović, State University of Novi Pazar

e-mail: sibela_np@yahoo.com

Lector:

Published by the State University of Novi Pazar, Vuka Karadžića bb,
Novi Pazar 36 300, Serbia.

Printed by Sven, Niš, Serbia

Editorial Board

Ravi P. Agarwal (USA)

Vladimir V. Amelkin (Belarus)

Dragan S. Antić (Serbia)

Anatoli B. Antonevich (Belarus)

Alejandro A. Castillo Atoche (Mexico)

Vukota M. Babović (Serbia)

Žarko P. Barbarić (Serbia)

Michael P. Bekakos (Greece)

Dragan S. Djordjević (Serbia)

Vladan Djordjević (Serbia)

Jakov Đuhovnik (Slovenia)

Igor V. Gatskun (Belarus)

Milica J. Jelić (Serbia)

Jean-Pierre Lemerle (France)

Ralf P. Lührer (Germany)

Frank E. Matić (Germany)

Miroslav S. Mantić (Serbia)

Miroslav S. Mateljević (Serbia)

Sašo Medved (Slovenia)

Ivan Z. Milentjević (Serbia)

Bratislav D. Milovanović (Serbia)

Igor Ž. Milovanović (Serbia)

Marko Nedeljkov (Serbia)

Predrag Osmokrović (Serbia)

Miroslav Petrović (Serbia)

Miroslava Petrović-Torgašev (Serbia)

Mileva S. Prvanović (Serbia)

Marko Robnik (Slovenia)

Valery G. Romanovsky (Slovenia)

Michael Ruzhansky (UK)

Stanislav G. Sedukhin (Japan)

Alexey A. Tikhonov (Russia)

Teufik I. Tokić (Serbia)

Miloš S. Čanak (Serbia)

Miroslav D. Ćirić (Serbia)

Marian Vajtersic (Austria)

Veljko Vujičić (Serbia)

SCIENTIFIC PUBLICATIONS OF THE STATE UNIVERSITY OF
NOVI PAZAR
SERIES A: APPLIED MATHEMATICS, INFORMATICS AND MECHANICS

Contents

Volume 4, Issue No.2
Special Issue devoted to CPMMI 2012

INVITED PAPERS

- P.P. Zabreiko, A.V. Krivko-Krusko
Finite Systems of Equations and Implicit Functions 1
- T. M. Atanacković, S. Pilipović, D. Zorica
*Vibrations of a System: Viscoelastic Rod of Fractional Type and a
Body Attached to the Rod* 27

REGULAR PAPERS

- A. Yu. Aleksandrov, A. A. Kosov
*Stability of Equilibrium Positions of Mechanical Systems with Switched
Force Fields* 35
- I. Ž. Milovanović, Č. B. Dolićanin, M. K. Stojčev, E. I. Milovanović
Modification of Euclidian Algorithm for Solving Modular Equations 41
- I. A. Soloviev
*Stochastic Stability Conditions for Solutions of Differential Equations
for Means* 45
- K. A. Antipov, A.A. Tikhonov
*On Analytical Investigation and Computer Modeling in the Problem
of the Satellite's Attitude Stabilization* 49
- D. Antić, M. Milojković, D. Mitić, Saša Nikolić, S. Perić
Sliding Mode Control Based on Orthogonal Models 55
- M. Mijajlović, D. Milčević, V. Nikolić-Stanojević, M. Milčević
*Numerical Simulation of Friction Stir Welding on Aluminum Alloy
2024-T351 Plates* 65

Numerical Simulation of Friction Stir Welding on Aluminum Alloy 2024-T351 Plates

M. Mijajlović, D. Milčić, V. Nikolić-Stanojević, M. Milčić

Abstract: Friction stir welding is a solid-state welding technique that utilizes thermo-mechanical influence of the rotating welding tool on parent material resulting with monolith joint - weld. On the contact of welding tool and parent material, significant stirring and deformation of parent material appears, and during this process mechanical energy is partially transformed into heat. Generated heat affects the temperature of the welding tool and parent material so proposed analytical model for estimation of the amount of generated heat can be verified by temperature: analytically determined heat is used for numerical estimation of the parent material's temperature and this temperature is compared to the experimentally determined temperature. Numerical solution for analytical estimation of welding plates temperature is estimated using finite difference method - explicit scheme with adaptive grid, considering influence of temperature on material's conductivity, contact conditions between welding tool and parent material, material flow around welding tool etc.

Keywords: Friction Stir Welding, Numerical Simulation, 2024-T351, Finite Difference Method

1 Introduction

Friction Stir Welding (FSW) is a solid state welding process predominantly used for welding of aluminium, aluminium alloys and other soft metals/alloys. This welding technique requires usage of specialized, cylindrical – shouldered tool, with a profiled threaded/unthreaded probe (Figure 1). Welding tool is rotated at a constant speed and fed at a constant traverse speed into the joint line between two welding plates (workpieces), which are butted together. The parts are clamped rigidly onto a backing plate (anvil) in a manner that prevents the abutting joint faces from being forced apart. The length of the probe is slightly less than the weld depth required and the tool shoulder should have contact with the work surface. The probe is moved against the weld – joint line, or vice versa. While traveling, welding tool stirs, deforms and mixes the material of the workpieces into the monolith mixture that represents the weld.

Manuscript received March 14, 2012 ; accepted may 23, 2012.

M. Mijajlović, D. Milčić, M. Milčić are with the University of Niš, Faculty of Mechanical Engineering, Niš, Serbia; V. Nikolić-Stanojević is with the State University of Novi Pazar, Novi Pazar, Serbia.

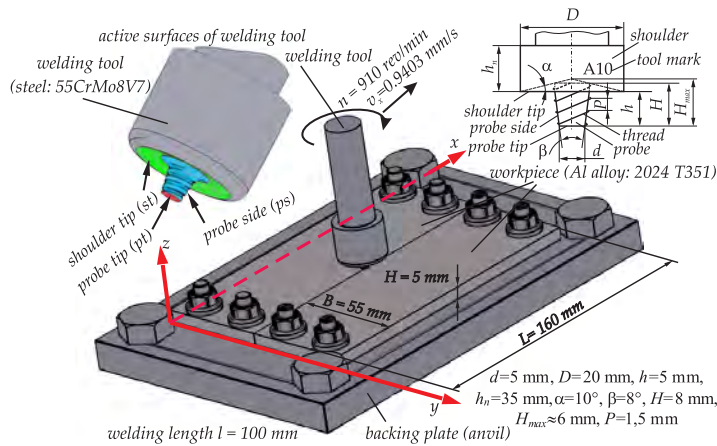

Fig. 1. rinciple of the FSW, welding tool and active surfaces of the welding tool

As a solid state welding procedure, FSW uses pure mechanical energy as welding process activation energy and distributes it from the welding machine to the base material (workpieces) over the welding tool. However, only one part of the mechanical energy is used directly as a mechanical energy while the rest of it is transformed in other types of energy: into heat, light, electricity, radiation etc. Researches, experience and engineering practice have shown that, as a result of any kind of energy transformation, direct or indirect product of energy use is transformation of input energy into heat, partially or almost completely. This is a phenomenon that appears during the FSW process as well: mechanical energy given to the welding tool is dominantly used for deformation and mixing of the particles chopped from workpieces during contact of the welding tool and workpieces, the rest of energy is transforming into heat and some of it is transformed in other types of energy (Figure 1).

Primary transformation of the mechanical power into heat happens on the intimate contact of the welding tool and workpieces or in a thin layer of the softer material (in this case it is the material of workpieces) near the welding tool (Figure 2). This layer represents primary heat generation sources. Secondary transformation of power into heat happens in the volume of deformed material of workpieces and moving particles of workpieces' material represent secondary heat generation sources.

2 Analytical model for estimation of amount of generated during FSW

Heat generation process at FSW has been partially investigated at the beginning of 2002 for the first time [3]. This happened 11 years after invention of the FSW.

Until present days, there are three (four) published analytical models for estimation and assessment of amount of heat generated during FSW [3, 7, 8]. All of them differently approach to the heat generation in FSW, however, all of them consider heat generation in FSW as a process tightly connected with the contact mechanics, tribology, plastic deforming

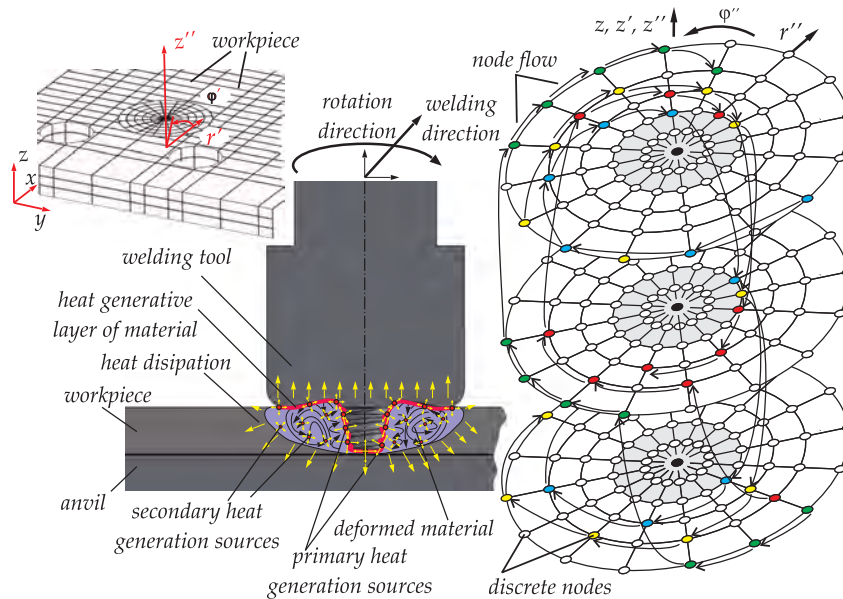

Fig. 2. pace discretization, heat generation and material flow pattern - node substitution and replacement during FSW

and thermodynamics of deformable bodies. These models show that 60% to 100% of the mechanical power transform into heat during FSW.

Analytical model developed at Faculty of Mechanical Engineering Nis is the fourth published model for estimation of amount of heat generated during FSW [4, 5, 6]. As well as first three models, it relies on the conservation of mechanical energy postulate and starts from the assumption that in theory complete amount of mechanical energy delivered to the welding tool transforms into heat. In reality, one part of mechanical energy is used for other processes that appear during welding what gives that at most the rest of the mechanical energy can be transformed into heat. In order to estimate maximal possible amount of generated heat during FSW (for certain technological parameters of the process), this model takes into consideration influence of the welding tool to the process of welding, loads, tribological parameters, temperature of workpieces, material flow around the welding tool, heat generation mechanisms etc.

3 Numerical simulation of FSW

Estimation of the amount of generated heat during FSW is basing on analytical expressions that give the amount of heat generated on active surfaces of the welding tool. Due to the numerous parameters involving transformation of mechanical energy into heat, complex mutual dependences between these parameters, as well as the fact that heat generation in FSW is highly process-realization dependent phenomena, analytical estimation of amount of heat generated during FSW is iterative and discrete process. For example, temperature

of workpieces is important for the FSW process and estimation of temperature requires solving heat equation. Heat equation is differential equation that has algebraic solutions for limited cases and usually is solved numerically. Even more complex challenge is estimation of heat transfer thru the workpieces initiated with the material flow around the welding tool: it is necessary to recognize material flow patterns, dependences between welding tool, technological parameters of welding process and material properties etc, and then to connect heat transfer with mass transfer.

Material flow in FSW was explained by many [1, 2, 8, 9, 10], however, there is no adequate mathematical model capable to fully describe it. Present works on FSW either neglect the influence of material flow or simplify the material flow patterns considering it purely rotational around the welding tool. Faculty of Mechanical Engineering in Nis has proposed a new numerical procedure for implementation of material flow pattern into numerical simulations of FSW. Procedure is called - node substitution and replacement [6] and uses experimental results, probabilistic theory, technological parameters of the FSW, geometry of the FSW tool etc. to estimate material flow pattern around the FSW tool. The main goal of the procedure was to improve accuracy of the numerical simulation.

All these procedures are numerical and when implemented in analytical model for heat estimation they are part of the numerical simulation of FSW that has a goal estimate amount of heat generated during FSW.

As process-realization dependent phenomena, heat generation during FSW influences analytical model for amount of generated heat estimation to use experimental data of FSW for proper precision (Figure 3). Table 1 shows some important parameters necessary for the numerical simulation.

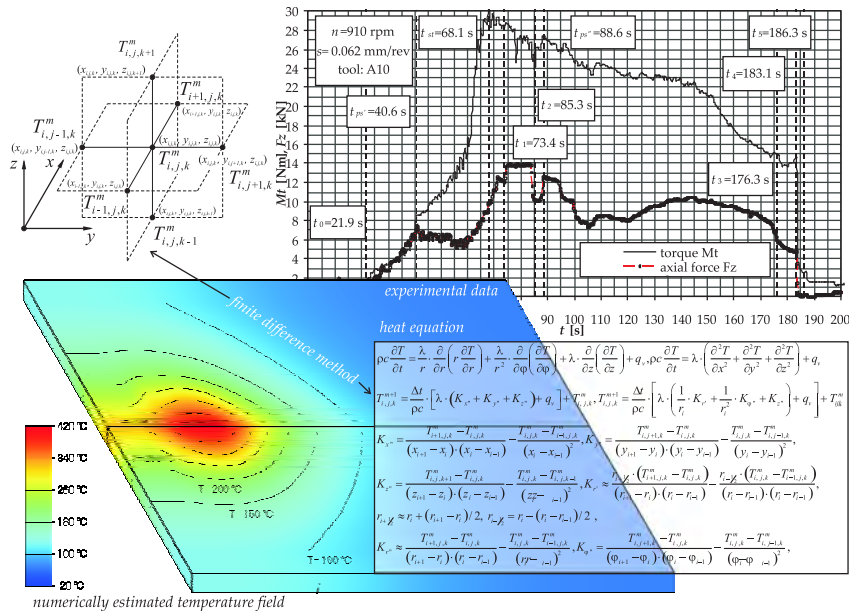

Fig. 3. Numerical simulation of the FSW

Table 1. SIMULATION PARAMETERS

T, [° C]	24	100	149	204	260	316	371	400
$\sigma_{yield}(T)$, [N/mm ²] / no plastic strain	345	331	310	138	62	41	28	21
$\sigma_{yield}(T, \epsilon)$, [N/mm ²] / plastic strain ϵ	483 / 0.18	455 / 0.16	379 / 0.11	186 / 0.23	76 / 0.55	52 / 0.75	34 / 1.00	25 / 1.00
Convection coefficient	$\alpha = 10\text{W}/(\text{m}^2\text{K})$, $\alpha_{approx}=1500\text{W}/(\text{m}^2\text{K})$							
Nominal TP* of welding plates:	$\lambda_{pt} = 121\text{W}/(\text{mK})$, $\rho_{pt} = 2780\text{kg}/\text{m}^3$, $c_{pt} = 875\text{J}/(\text{kgK})$							
Nominal TP of welding tool:	$\lambda_{wt} = 38\text{W}/(\text{mK})$, $\rho_{wt} = 7840\text{kg}/\text{m}^3$, $c_{wt} = 500\text{J}/(\text{kgK})$							
Material and diameter of bolts:	S335 EN 10025, $d_z=10\text{mm}$							
Nominal TP of bolts:	$\lambda_{bt} = 43\text{W}/(\text{mK})$, $\rho_{bt} = 7850\text{kg}/\text{m}^3$, $c_{bt} = 420\text{J}/(\text{kgK})$							
Important dimensions and material of anvil:	$L_a=220\text{mm}$, $B_a=148\text{mm}$, $H_a=16\text{mm}$, X5CrNi18-10							
Nominal TP of anvil:	$\lambda_a = 18\text{W}/(\text{mK})$, $\rho_a = 8030\text{kg}/\text{m}^3$, $c_a = 500\text{J}/(\text{kgK})$							
Minimal discretization dimensions / time step:	$\Delta x_{min} = 3\text{mm}$, $\Delta y_{min} = 1.5\text{mm}$, $\Delta z_{min} = 1.5\text{mm}$; $\Delta t = 0.0055\text{s}$							
Adaptive discretization parameters:	$\epsilon_x = -1, 1, 5/3, 7/2$; $\epsilon_y = -4/3, 1, 5/3, 2, 10/3, 16/3, 20/3$; $\epsilon_z = -1, 1$;							
Convergence of FDM**:	$\lambda_{pt} \cdot \Delta t / (\rho_{pt} \cdot c_{pt} \cdot \Delta x_{min}^2) = 0.03$; $1/6 = 0.167$ $\lambda_{pt} \cdot \Delta t / (\rho_{pt} \cdot c_{pt} \cdot \Delta y_{min}^2) = 0.122$; $1/6 = 0.167$ $\lambda_{pt} \cdot \Delta t / (\rho_{pt} \cdot c_{pt} \cdot \Delta z_{min}^2) = 0.122$; $1/6 = 0.167$							
Number of nodes/iterations:	$n_{nod} = 14160 / n_{iter} = 28528$							
Approximate calculation time	$t_{calc} = 1283760\text{s}$ (14 d 20 h 36 min) (processor: $2 \times 2.30\text{GHz}$)							

*TP – thermomechanical properties, **FDM - finite difference method

4 Discussion and conclusions

Analytical model for the estimation of amount of heat generated during FSW has shown that 60-100% of mechanical power delivered to the welding tool transform into heat. Median value of heat transformation is 86.58% (during plunging phase 79.27%, first dwelling 90.10%, welding 90.25%, second dwelling 90.94%, and pulling out 52.92%). Numerical simulation of FSW included well known finite difference method for numerical estimation of temperatures in discrete nodes of workpieces and accuracy of the simulation is improved by the innovative numerical method for material flow definition - node substitution and

replacements. Proposed analytical/numerical model for temperature estimation gave numerically estimated temperature that varies up to 11% from experimentally estimated temperature (that is about 15 °C as absolute error). Maximal temperature on welding plates was numerically estimated $T_{max}= 393,538$ °C, what is about 80% of Al 2024 T351 melting point. Maximal temperature of the welding tool was experimentally measured $T_{max} = 464$ °C.

References

- [1] K. COLLIGAN, *Dynamic material deformation during friction stir welding aluminium*, Proc. 1st Int. Symp. on Friction Stir Welding, Thousand Oaks, USA 1999.
- [2] P.A. COLEGROVE, H. R. SHERCLIF, , *3-Dimensional CDF modelling of flow round a threated friction stir welding tool profile*, J. Mater. Process. Tech., v.169, (2005), 320-327, .
- [3] M. SONG, R. KOVAČEVIĆ, *Thermal modeling of friction stir welding in a moving coordinate system and its validation*, Int. J. of Machine Tools & Manufacture, Vol. 43,(2003), 605-615.
- [4] M. MIJAJLOVIĆ, et all, *Mathematical Model for Analytical Estimation of Generated Heat During Friction Stir Welding. Part 1*, Journal of Balkan Tribological Association, Vol. 17, No 2, (2011), 179-191,
- [5] M. MIJAJLOVIĆ, et all, *Mathematical Model for Analytical Estimation of Generated Heat During Friction Stir Welding. Part 2*, Journal of Balkan Tribological Association, Vol. 17, 3, (2011), 361-370,
- [6] M. MIJAJLOVIĆ, M, *Investigation and development of analytical model for estimation of amount of heat generated during FSW*, PhD thesis, University of Nis, Faculty of Mechanical Engineering Nis, 2012.
- [7] H. SCHMIDT, J. HATTEL, J. WERT, *An analytical model for the heat generation in Friction Stir Welding*, Modeling Simul. Mater. Sci. Eng., Vol 12, 1, (2004),143-157.
- [8] R. NANDAN, et all, *Three-dimensional heat and material flow during friction stir welding of mild steel*, Acta Materialia, Vol 55, (2007), 883-895.
- [9] J.H.OUYANG, R. KOVAČEVIĆ, *Material Flow and Microstructure in the Friction Stir Butt Welds of the Same and Dissimilar Aluminum Alloys*, Journal of Materials Engineering and Performance, ASM International, Vol. 11, No. 1,(2002), 51-63.
- [10] P. ULYSSE, *Three-dimensional modeling of the friction stir-welding process*, Int. J. Mach. Tool. Manu. Vol 42, (2002), 1549-1557.
- [11] M. DJURDJANOVIĆ, et all, *Heat Generation During Friction Stir Welding Process*, Tribology in Industry Journal, Vol. 31, (2009), 8-14.