

ZVEZA DRUŠTEV ZA VARILNO TEHNIKO SLOVENIJE
CELJSKI SEJEM d.d.



5 Mednarodni sejem

VARJENJE IN REZANJE

Tehnologija, oprema in materiali

Celje, 15.-18. maj 2012

**DAN
VARILNE
TEHNIKE
2012**

Zbornik predavanj

Stanje in trendi razvoja
v varilni tehniki

Celjski sejem d.d.
in
Zveza društvo za varilno tehniko Slovenije

DAN VARILNE TEHNIKE 2012

Zbornik predavanj

STANJE IN TRENDI RAZVOJA V VARILNI TEHNIKI

Celje, 17. maj 2012

Naslov: Dan varilne tehnike 2012 – zbornik predavanj

Organizatorja: Zveza društvo za varilno tehniko Slovenije in Celjski sejem d.d.

Uredniški odbor: Ivan Polajnar, Fakulteta za strojništvo, Univerza v Ljubljani
Marjan Suban, IMK
Sergeja Marjanovič in Breda Obrez Preskar, obe Celjski sejem d.d.

Programski odbor:

izr. prof. dr. Ivan Polajnar – predsednik
prof. dr. Mirko Čudina
prof. dr. Janez Diaci
prof. dr. Janez Grum
prof. dr. Isak Karabegović
prof. dr. Zoran Kožuh
prof. dr. Slobodan Kralj
prof. dr. Viljem Kralj
prof. dr. Džafer Kudumović
prof. dr. Nedjeljko Mišina
prof. dr. Inoslav Rak
prof. dr. Ivan Samardžić
izr. prof. dr. Sveto Cvetkovski
izr. prof. dr. Vladimir Gliha
izr. prof. dr. Janez Kramar
doc. dr. Primož Podržaj
dr. Venceslav Grabulov
dr. Arpad Köveš
mag. Mojca Šolar, univ. dipl. inž.
Marjan Brajdih, univ. dipl. inž.
Hubert Kosler, univ. dipl. inž.
Franci Krošelj, univ. dipl. inž.
Breda Obrez Preskar, univ. dipl. oec
Janez Orban, univ. dipl. inž.

Organizacijski odbor:

dr. Marjan Suban – predsednik
prof. dr. Darko Bajić
doc. dr. Damjan Klobčar
doc. dr. Jurij Prezelj
doc. dr. Gabriel Rihar
doc. dr. Tomaž Vuherer
dr. Ladislav Grad
dr. Jožef Horvat
dr. Bogdan Pučko
dr. Miro Uran
mag. Vlado Krebs
mag. Roman Krepek
Božo Despotović, univ. dipl. inž.
Anton Gros, univ. dipl. inž.
Jože Kočevar, dipl. inž.
Peter Opaka, univ. dipl. inž.
Sergeja Marjanovič, univ. dipl. oec
Matej Pečnik, dipl. inž.
Peter Šprajc, dipl. inž.
Štefan Vučak, dipl. inž.
Breda Žgeč, univ. dipl. inž.
Klemen Zorko, univ. dipl. inž.
Miha Pesek
Viljem Šeter

Oblikovanje: dr. Marjan Suban
Oblikovanje naslovnice: Sergeja Marjanovič
Založnik: Celjski sejem d. d., Celje
Tisk: Kotis d.n.o.
Naklada: 100 izvodov

CIP - Kataložni zapis o publikaciji
Narodna in univerzitetna knjižnica, Ljubljana

621.791(082)

DAN varilne tehnike (2012 ; Celje)

Stanje in trendi razvoja v varilni tehniki : zbornik predavanj

/ Dan varilne tehnike 2012, Celje, 17. maj 2012 ; [organizatorja]

Celjski sejem [in] Zveza društev za varilno tehniko Slovenije ; [uredniški odbor Ivan Polajnar ... et al.]. - Celje : Celjski sejem, 2012

ISBN 978-961-91552-8-8

1. Gl. stv. nasl. 2. Polajnar, Ivan 3. Zveza društev za varilno tehniko Slovenije 4. Celjski sejem
261664000

VSEBINA

Inoslav Rak Uvodna beseda	1
-------------------------------------	---

In memoriam	3
--------------------	---

IZOBRAŽEVANJE IN STANDARDIZACIJA

Uran Miro, Jovanović Miloš, Šprajc Peter, Köves Arpad, John B. Stav Neuradno priznano izobraževanje in tehnologije uporabljene v izobraževanju in certificiranju varilnega osebja	5
Arpad Kövesh Novi pristopi na področju izobraževanja varilcev in varilskih tehnologov	11
Gabriel Rihar Kaj prinaša standard EN 1090-1	15
Božo Despotović, Stjepan Gangur, Dalibor Birač Osiguranje kvalitete u tehnici zavarivanja s aspekta certificiranih kadrova	17

VIRI TOKA

Danijel Langus, Arpad Koveš, Ivan Polajnar, Marjan Golob Simulacija izvedbe pulznega MIG/MAG varjenja s tiristorskim virom toka	23
Božo Despotović, Vedran Rajković Primjena „CMT“ procesa pri navarivanju cijevnih zidova	27
Renato Pahor Kemppi - dodatna programska oprema – posebne rešitve	33
Milan Skubin, Daniel Skubin, Egon Kariž, Anja Sterle, Ivan Polajnar Namizni stroj za uporovno točkovno varjenje	39

AVTOMATIZACIJA IN ROBOTIZACIJA

Isak Karabegović, Edina Karabegović Aplikacija industrijskih robota u procesu zavarivanja na kontinentu Azija/Australija	43
Tjaša Kodrič, Hugo Zupan, Tomaž Bren Avtomatizacija in robotizacija varjenja	49
János Orbán Povečanje produktivnosti pri termičnem rezanju debelejših pločevin – primeri iz prakse	55
Jože Treiber, Robert Halas, Rudolf Imre, Damjan Zadavec, János Orbán Robotski sistem za večslojno varjenje velikih in težkih izdelkov – primer iz prakse	63

NAPETOSTI IN DEFORMACIJE

Tomaž Vuherer, Milorad Zrilić, Darko Bajić, Vladimir Gliha Uporabnost metode vrtanja izvrtine za merjenje zaostalih napetosti na varjenih konstrukcijah na terenu	69
Igor Križman, Martin Strašek Spajanje pocinkanih HOP profilov	75

VARIIVOST IN TEHNOLOŠKE REŠITVE

Mojca Šolar, Jožica Cankar, Marjan Bergant, Edvard Bjelajac Varjenje drobnozrnatih materialov	79
Igor Marinšek Varjenje aluminija s talilnimi postopki	85
Ladislav Šiško, Ivan Polajnar, Janez Grum Osnovne varilno-tehnične značilnosti bakra	89
S. Cvetkovski, L.P. Karjalainen Implementation of adams' equation for determination of heat input in laser welding of Optim 355MC steel	95
Benjamin Černoša, Matej Kos Varjenje lesa	103
Miroslav M. Mijajlović, Dragan. S. Milčić Friction Stir Welding of aluminium alloy 2024 T351	109
Džafer Kudumović, Elvedin Trakić, Besim. Demirović Tehnologija zavarivanja primarnih konstruktivnih elemenata vodotoranja , v = 500 m3 izrađenog od čelika	115
Milan D. Milovanovic, Dragan Milosavljević Koriščenje termičkog naprskavanja za revitalizaciju različitih elemenata	121
Jakob Mostar O popravilih poškodovanih zvonov	127

SPREMLJANJE IN ZAGOTAVLJANJE KAKOVOSTI

Iztok Palčič, Zdenko Kumer Optimizacija ter možnost zmanjšanja stroškov pri izdelavi zvarjencev?	129
Ivan Tomašič Trendi pri izdelavi hidroenergetske opreme	135
Tit Črtomir Kanduč, Jurij Prezelj, Mirko Čudina, Ivan Polajnar Vpliv zunanjega zvočnega polja na varjenje po postopku TIG	141
Vlado Krebs Točkovno uporovno varjenje heterogenih materialov za dele gospodinjskih aparatov	145
Vilijem Čibej, Edvin Batista, Ivan Polajnar, Janez Diaci Izboljšava tehnologije uporovnega varjenja diod na usmernik	151

OKOLJE, VARNOST IN ZAŠČITA

Marjan Suban, Robert Cvelbar, Borut Bundara Primerjava varjenih in vijačnih konstrukcijskih spojev z vidika vpliva na okolje	157
Rok Lužar, Franjo Lužar Kakovostna zaščitna oprema – investicija v zdravje varilcev in višjo storilnost	163
	107

Friction Stir Welding of aluminium alloy 2024 T351

Miroslav M. Mijajlović, Dragan. S. Milčić

Univeristy of Niš, Faculty of Mechanical Engineering Niš, Aleksandra Medvedeva 14, 18000 Nis, Serbia

Summary

Aluminium alloys from class 2xxx are strong, limitedly machinable and non-weldable metallic materials widely used in shipbuilding, railway, automotive and aero industries. Representative of this class is alloy 2024 T351, used in aircraft structures, especially wing and fuselage structures under tension. However, alloy 2024 T351 is limitedly weldable by gas tungsten arc welding process and very poorly by shielded metal arc welding process. Friction stir welding is a solid state welding technique primarily used for welding of aluminium and its alloys. This paper is giving an overview on friction stir welding process applied on welding of plates made of aluminium 2024 T351.

1. INTRODUCTION

Friction stir welding (FSW) is a solid-state welding technique introduced during 1991-1992 by TWI London. First application of the FSW was welding of long aluminium sheets used for railway vehicles in Japan; after that FSW was introduced by marine, aero, space, automobile and other industries around the globe. From that time, FSW is widely known as welding technique mostly used for welding of aluminium and its alloys. However, there are numerous examples of steel, bronze etc. jointed by FSW [1].

FSW is widely used for the joining of softer metals such aluminium and aluminium alloys are. Aluminium alloys are always a challenge for welding, without concern on weldability of base metal. Like other arc welding processes, FSW is applicative for welding of 5xxx and 6xxx series of Al alloys but its advantages over other processes are seeable when welding 2xxx class of Al alloy. A representative of the 2xxx class is alloy 2024 and it is widely used in FSW processes.

1.1. Alloy 2024 T351

Aluminium alloy 2024 is an Al alloy, with Cu and Mg as the alloying elements. It is used in applications requiring high strength to weight ratio, as well as good fatigue resistance. It is not weldable, and has average machinability. Due to poor corrosion resistance, it is often clad with Al or Al-Zn for protection, although this procedure may reduce the fatigue strength. It has a density of 2.73 g/cm³, Young's modulus of 73 GPa across all tempers, and begins to melt at about 500 °C. Because the material is susceptible to thermal shock, 2024 is used in qualification of liquid penetrant tests outside of normal temperature ranges.

Table 1. Chemical composition and mechanical properties of alloy Al 2024 T351

Chemical composition		Mechanical properties	
Chemical element	Mass %		
Al	~	0.2% Proof Stress $R_{p0.2}$	266-274 N/mm ²
S	0.12		
Fe	0.28		
Cu	4.52	Tensile Strength R_m	404-424 N/mm ²
Mn	0.65		
Mg	1.60		
Cn	0.01		
Zn	0.09	Elongation A_5	22.00%
Ti	0.016		
B	0.009		
N	0.02		

Data in Table 1 is taken from the Approved Certificate data: Alcoa International, inc, No 47831, for sheet of 2100 mm × 6000 mm × 8mm, material EN AW 2024 T351 used for the FSW process (experiments).

1.2. Principle of the FSW

At the beginning of the welding process, welding tool is mounted into the rotating head of the machine, placed above the joint line on the fixed welding plates and probe tip barely touches the top of the welding plates (Figure 1, a). The main rotation axis of the welding tool is perpendicular with welding plates and the joint line. In that position, welding tool starts to rotate (n revolutions per min). Probe of the welding tool (Figure 1, b) plunges in the welding plates (base metal, workpieces) at the start point on the joint line. Friction between probe and the welding plates initiates heat generation, welding plates soften in the area of friction contact between tool and plates and thread on the probe stirs the material of welding plates. When shoulder tip touches welding plates and probe tip is very close to the backing plate, plunging of the welding tool into the welding plates (base metal) stops and tool starts translation along the joint line. Moving along the joint line, weld tool's probe heats material from the welding plates, cuts and stirs layers from it and creates a vale of mixed and plasticized metal which hardens and creates monolith connection between welding pieces – weld. Shoulder tip confines upper surface of the weld while backing plate holds welding plates and confines lower surface of the weld as well. Welding process is finished when welding tool stops translation and after pulling out the tool from the joint line weld is completely finished.

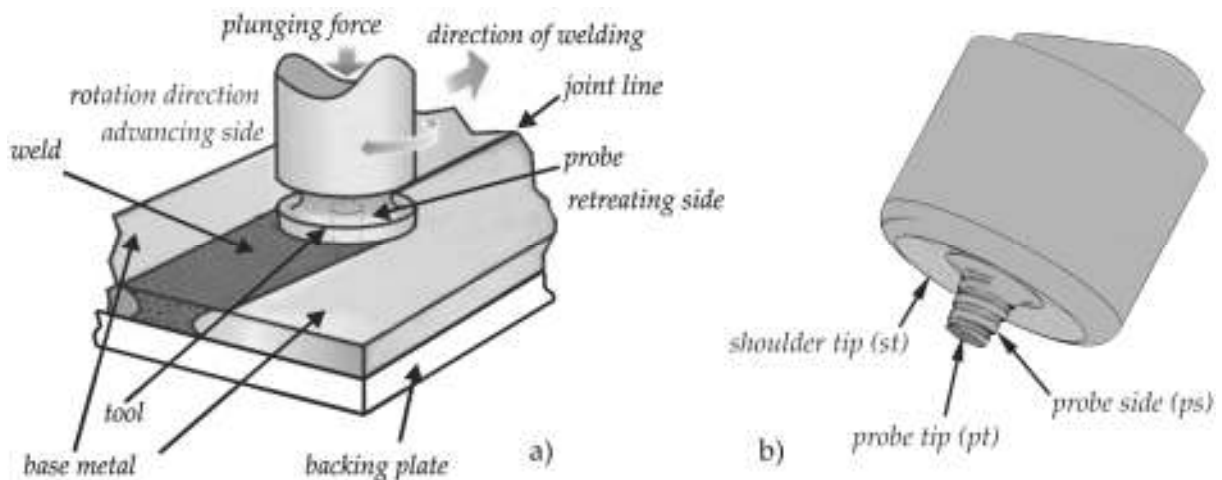

Figure 1 Friction stir welding: a) principle of the FSW, b) welding tool and its active surfaces [2]

2. FSW applied on the 2024 T351

Experimental studies (welding of plates prepared for experimental researches) were performed on plates with dimensions $L \times B \times H = 160 \text{ mm} \times 55 \text{ mm} \times \approx 6 \text{ mm}$, at welding length of $l = 100 \text{ mm}$. There are various designs of the FSW welding tools [1], however, Živković has shown that best results on FSW welding on Al 2024 T351 are achieved with welding tool with the cone probe, rounded thread on the probe side and confined shoulder tip [3]. For study of heat generation during FSW experimental researches were been started with the two different types of welding tool - theoretical (cylindrical probe, no thread, marked as A19, schematic shown in Figure 2) and welding tool given by Živković (marked as A10, schematic shown in Figure 2). Both types of welding tools are made of steel 56NiCrMoV7, annealed and tempered.

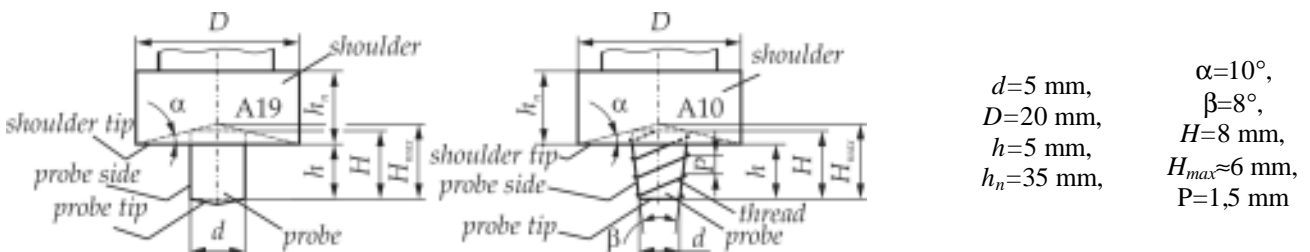

Figure 2 Schematic of welding tools [2] used in experimental studies

As expected, welding tool A19 has cracked during first welding and further experimental studies were conducted only with the welding tool A10.

Experimental studies had three main directions: estimation of parameters important for heat generation process in FSW, measuring intensity and trends of these parameters and creation of qualitative weld on 2024 alloy. It

was concluded [2] that axial force on welding tool, torque, welding force, friction coefficient and temperature of workpieces and welding tool are the most important parameters that have to be experimentally determined. Due to the complexity of the FSW kinematics, selected parameters and dimensions of the measuring equipment, it was concluded that welding should be performed in configuration where axis of the welding tool is horizontal. Such a demand has point out the lathe as the working machine, what is, probably, the first application of the lathe for FSW. Figure 3 gives a schematic of the horizontal working place and measuring configuration for torque and axial force (z - direction).

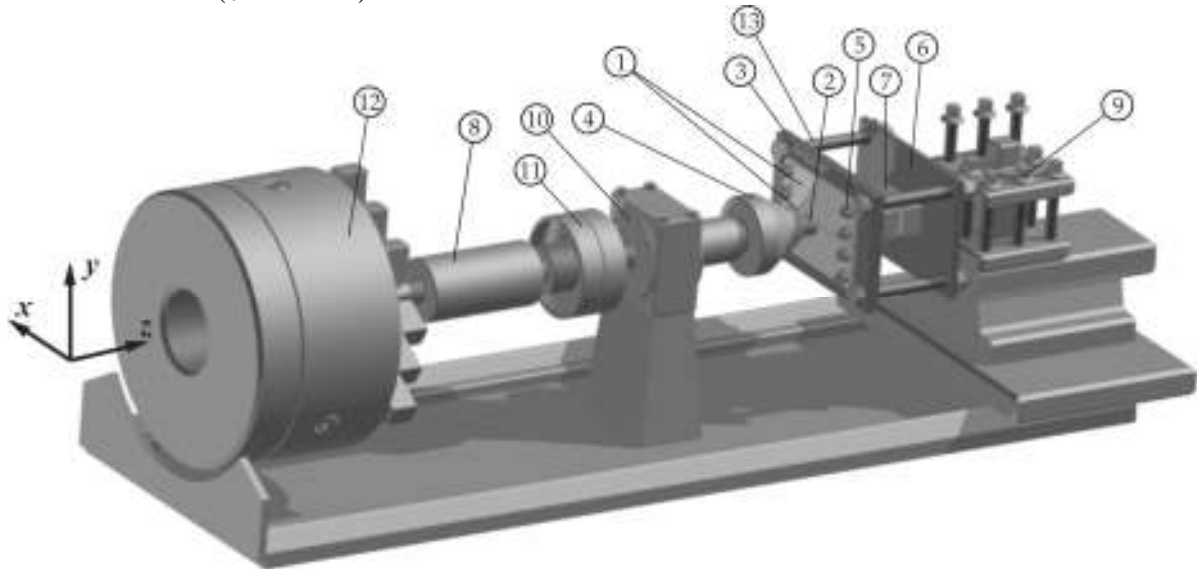

Figure 3 Measuring configuration for torque and axial force: 1-workpiece, 2-welding tool, 3-anvil, 4-welding tool's spindle, 5-bolts, 6-backing plate, 7-force sensor, 8-torque sensor, 9-machines tool rest, 10-axial bearing, 11-clutch, 12-machine's spindle, 13-fundamental bolts

Other mentioned parameters were measured at the same working place, with minor adaptations of the equipment.

Technological parameters of the FSW process (travel speed, tool rotation speed, tilt angle etc.) were selected from the range of suggested values [3]. Welding was performed with the “try and error” principle: the first attempt was with minimal technological parameters, when finished weld was inspected visually and with ultrasound and new parameters were selected for the new attempt. After seven attempts, optimal technological parameters were found what resulted in qualitative welded joints. Table 1 is giving some main recommendations for technological parameters, selected optimal technological parameters and maximal values of torque, axial force and welding force achieved during welding.

Table 1 Proposed technological parameters for welding of Al 2024 T351 [3, 2]

	Recommended diapason	Optimal values	Maximal measured values
Tool rotation speed n	750-1180 RPM	910 RPM	Torque: $M_t = 35$ Nm, Axial force: $F_z = 15$ kN,
Plunging speed v_z	no recommended value	not determined	
Travel speed v_x	46-150 mm/min=0,77-2,5 mm/s	0,062 mm/rev.=0,9403 mm/s	Welding force: $F_x = 510$ N, Friction coefficient: $\mu = 0.9$
Tilt angle	$\leq 5^\circ$	$1^\circ - 2^\circ$	
Welding length l_{min}	50 mm	≈ 100 mm	$T_{max} = 394$ °C at workpieces $T_{max} = 464$ °C at welding tool

Figure 4 shows working machine with equipment for measuring, welding tool and workpieces. Figure 5 shows typical diagram of measured torque, plunging force (axial force) and mechanical power (integrated from the torque).

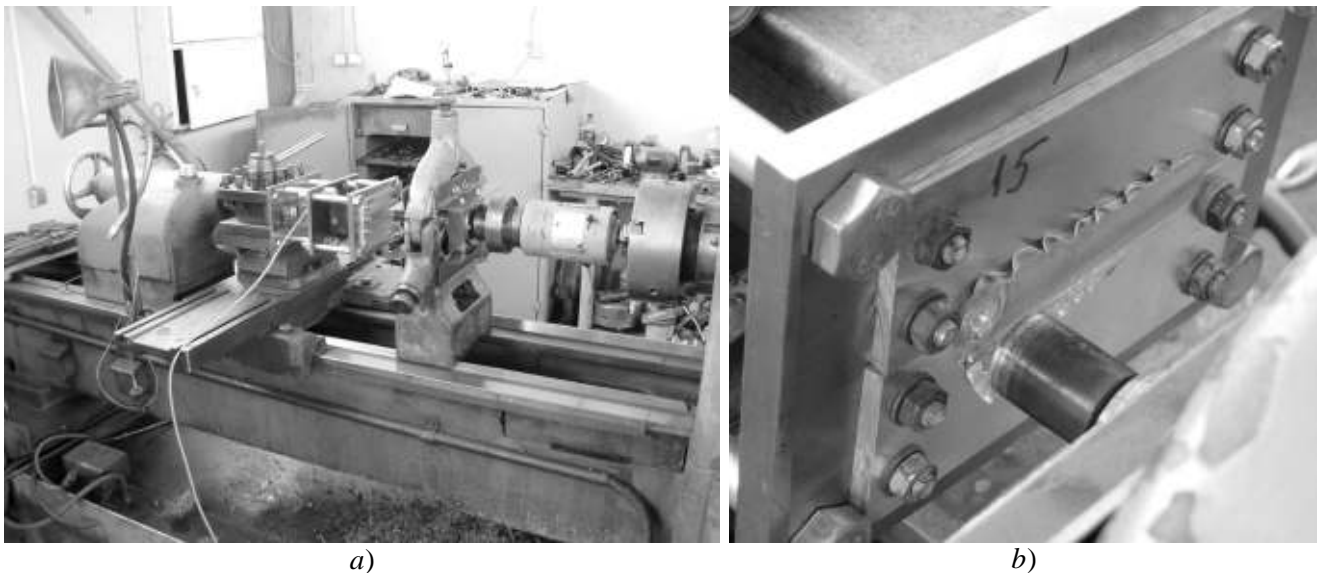

Figure 4 Working machine with mounted equipment for welding, measuring, welding tool and workpieces (a)

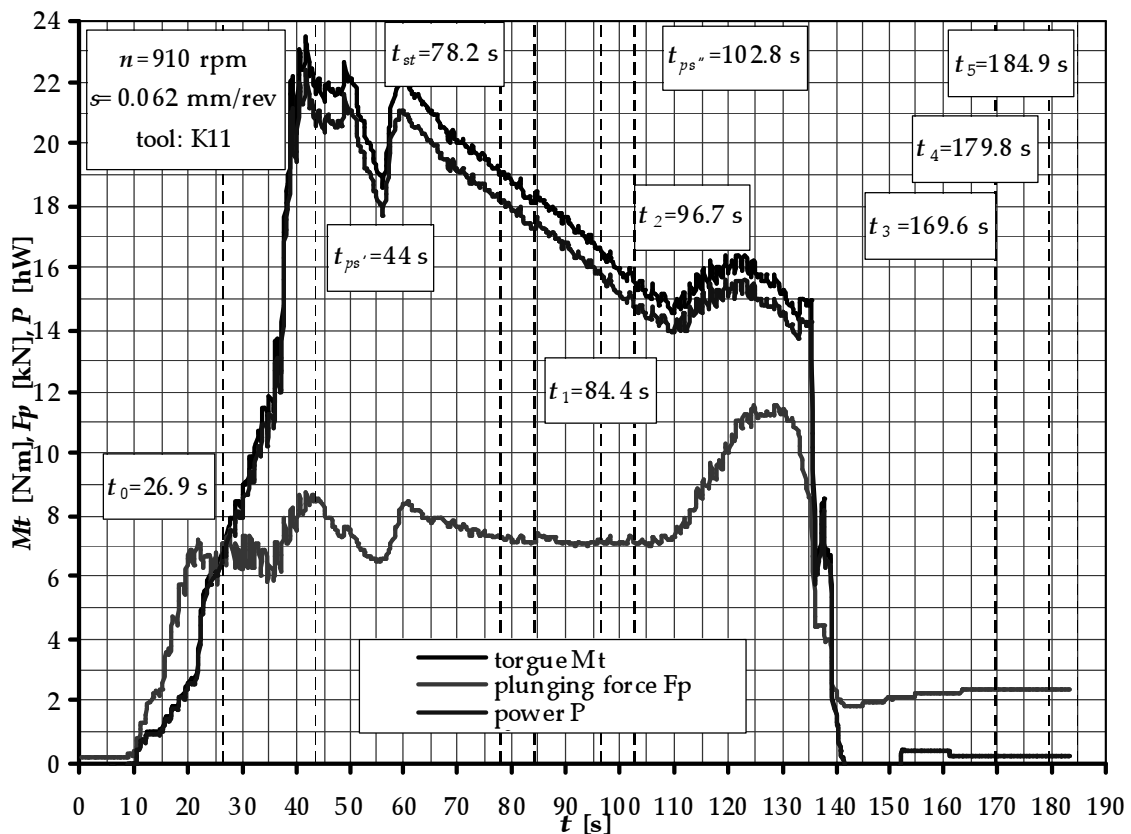

Figure 5 Typical diagram of torque, plunging force (axial force) and mechanical power

3. INSPECTION OF WELDED JOINTS

Since experimental studies and welding of 2024 alloy were performed before publishing of first FSW international standards [4-9], dimensions of the specimens used for non-destructive testing as well for the destructive testing, were not of standard values. Schematic, position in welded plates and dimensions of destructive test specimens used in studies are shown in Figure 6. Before specimen cutting, all welded joints were visually inspected, ultrasonically tested and some of joints were radiographically tested. Cut specimens were macro and micro inspected, tested for hardness, tensile and root/face bend tested.

All welded joints that were welded with the axial force higher than 14 kN during welding phase [2] have showed no cavity or incomplete joint penetration. Joints were tilt angle of welding tool was less than 1° have shown significant flash on face of the weld (like in Figure 4, b).

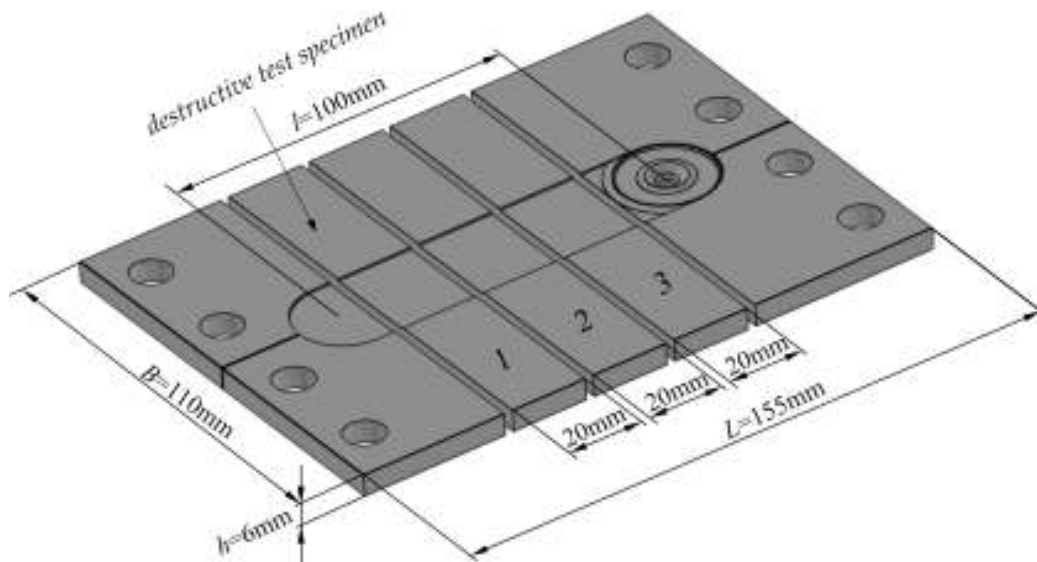

Figure 6 Schematic, position in welded plates and dimensions of destructive test specimens

Hardness of the specimens was different from specimen to specimen. Since weld nugget (specific microstructure of the weld, located approximately in the middle of the weld) has showed variation in dimension (larger at specimen 1, smaller at specimen 2 and smallest at specimen 3, near the end of the joint), expected “W” shaped hardness distribution along workpiece’s width is changing shape and dimensions (Figure 7, a, b and c)

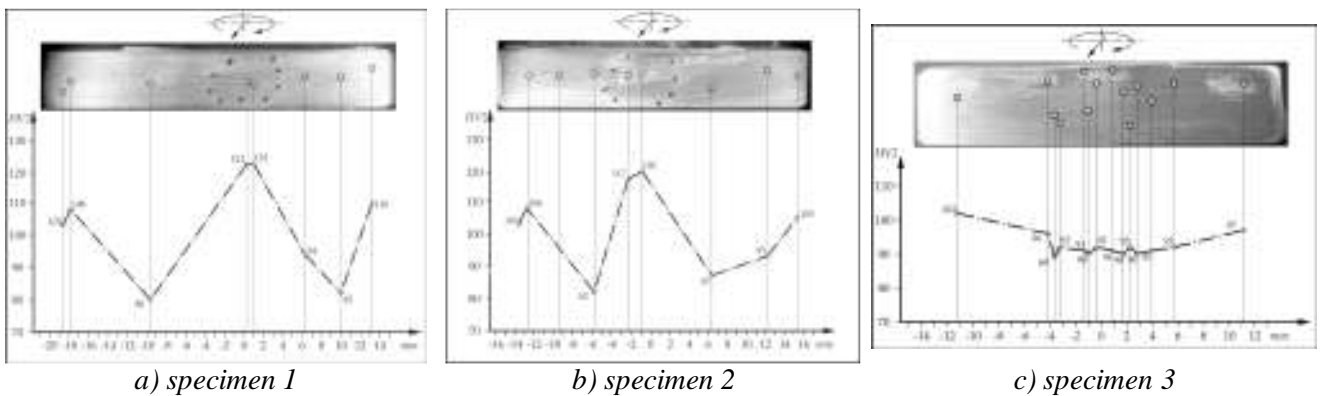

Figure 7 Hardness of the FSW weld, thermomechanically and heat affected zone, and parent material

Table 2 Results of the tensile testing and dimensions of the weld nugget

Intern welding mark (experiment number)	Specimen number (according to the Figure 6)	Experimental breaking force F_{ke} [kN]	Cross section of the specimen A_e [mm ²]	Ultimate tensile strength $R_{me} = \frac{F_{ke}}{A_e}$ [N/mm ²]	Dimensions of the nugget $b_j \times h_j$ [mm×mm]	Comment
K1119TO0	1	30,6	6 × 20 = 120	255	6 × 4.5	Specimen destruction happened in the weld
	2	32		266, 7	4.8 × 3.8	
	3	40,3		335,8	3.8 × 3.5	
K1120TO0	1	29,5		245,8	6 × 4.2	
	2	35,4		295	5.2 × 3.9	
	3	42		350	4.2 × 3.5	
K1121TO0	1	26,5		220,8	5.8 × 4.5	
	2	38		316,7	4.6 × 4.3	
	3	41,3		344,2	4 × 3.8	

Dimensions of the weld nugget in specimens 1, 2 and 3 are shown in Table 2 as well as details about the tensile tests on specimens. All specimens have cracked in weld, at the boundary of the weld nugget (Figure 8, a). Initial cracking might be on the root of the weld – all specimens cracked at straight line at the root side and micro cracks less than 0.2 mm long might have appeared due to the incomplete joint penetration (Figure 8, b).

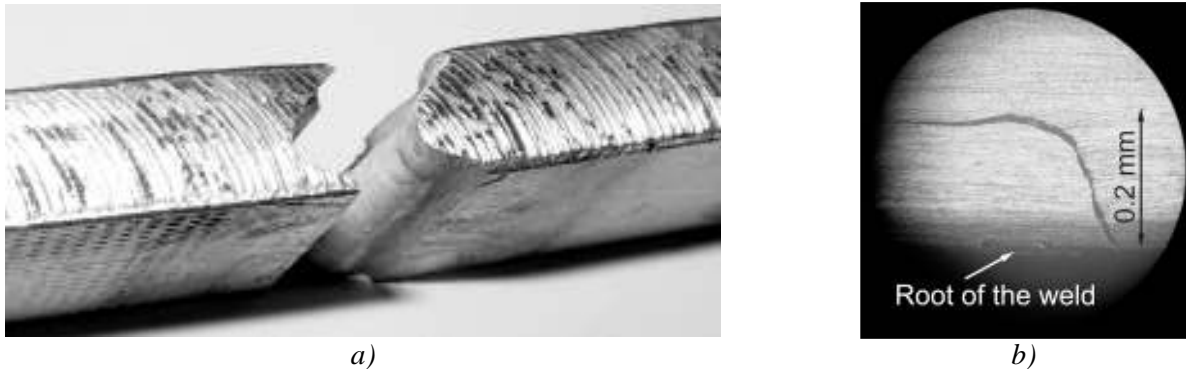

Figure 8 a) Tensile specimen – destroyed at the boundary of the weld nugget, b) micro cracking at root of the weld

Tensile tests have shown that efficiency of the weld varies from specimen to specimen. However, trend was the same for every experiment number: specimen 1 has tensile efficiency of app. 55%; specimen 2 has tensile efficiency of 60%-65% while specimen 3 has tensile efficiency of 70%-80%.

Face/root bending test has shown disastrous bending efficiency of 0%-12%. Bending angle for the root/face was maximally 11° while bending angle of the parent metal (pure workpiece specimens) was 88°-90°.

4. CONCLUSIONS

For purposes of development and verification of analytical model for estimation of amount of heat generated during FSW numerous experimental studies on welding of aluminium alloy 2024 T351 were performed. Studies were brief and included various methods and tools. The primary goal of experimental studies was to investigate parameters that dominantly influence heat generations while the secondary, but not less important than primary, goal was to perform welding on non-weldable alloy 2024 T351 and achieve satisfactory quality of the weld. Achieved results show that 2024 T351 alloy is difficult for welding, even with the FSW. Strength of the weld is questionable: welds show no imperfections, satisfactory tensile strength and poor bending strength. It is possible that weld nugget is dominantly influencing the strength of the weld – welds have much better properties when weld nugget has smaller dimensions. Further researches should be pointed out in direction of weld nugget dimensions decrease and investigation of the bending properties of the weld.

5. LITERATURE

1. Soundararajan, V., et al., “An Overview of R&D Work in Friction Stir Welding at SMU”, in MJoM, Metalurgija – Journal of Metallurgy, Association of Metallurgical Engineers of Serbia, Vol. 12, No. 204, 2006, pp. 277-295.
2. Mijajlović, M., Investigation and development of analytical model for estimation of amount of heat generated during FSW, Ph.D. thesis, University of Nis, Faculty of Mechanical Engineering Nis, 2012.
3. Živković, A: Influence of friction stir welding tool geometry on properties of welded joint of alloys Al 2024, Ph.D thesis, University of Belgrade, Faculty of Mechanical Engineering, 2011.
4. ISO 25239-1: 2011 Friction stir welding - Aluminium - Part 1: Vocabulary.
5. ISO 25239-2:2011 Friction stir welding - Aluminium - Part 2: Design of weld joints.
6. ISO 25239-3:2011 Friction stir welding - Aluminium - Part 3: Qualification of welding operators.
7. ISO 25239-4:2011 Friction stir welding - Aluminium - Part 4: Specification and qualification of welding procedures.
8. ISO 25239-5:2011 Friction stir welding - Aluminium - Part 5: Quality and inspection requirements.